



# Articulated Boom Lift

Model : DBA-12 / 6

PAP-A-5/4/5, Chakan Industrial Area, Phase-4, Nigoje Village, Tal - Khed, Pune - 410501

Contact: +91 8600117822 / 9011067039

Email: marketing2@daedalusind.com / sales@daedalusind.com

## Specifications

Models		DBA-12 / 6	
Measurements		Feet	Metric
Maximum Working Height*		39 ft	12 m
Maximum Platform Height		32 ft	10 m
Maximum Horizontal Outreach**		18 ft	5.6 m
Platform Length	A	2.9 ft	0.9 m
Platform Width	B	5.9 ft	1.8 m
Guardrail Height	C	3.6 ft	1.1 m
Height	Stowed	D	7.5 ft
Vehicle Dimensions	Height	D	7.5 ft
	Length	E	19 ft
	Width	F	6.5 ft
Wheelbase		G	6.5 ft
Ground Clearance		H	0.7 ft

## Productivity

Maximum Occupancy***		2 People
Lift Capacity		225 Kgs.
Platform Rotation		140 Degree
Vertical Jib Rotation		130 Degree
Turntable Rotation		340 Degree Non-Continuous
Gradeability****	Uphill	30%
Drive		4 WD
Drive Speed	Stowed	4.8 Kmph
	Raised	1 Kmph
Turning Radius	Outside	3.3 m
Control		24 V DC
Tyres (Solid Tyres)		23" X 10"

## Power

Power Source*****	8 X 6V 225 Ah Batteries
Auxiliary Power Unit	24 V DC
Hydraulic tank Capacity	60 Ltr.
Weight*****	7000 Kgs.

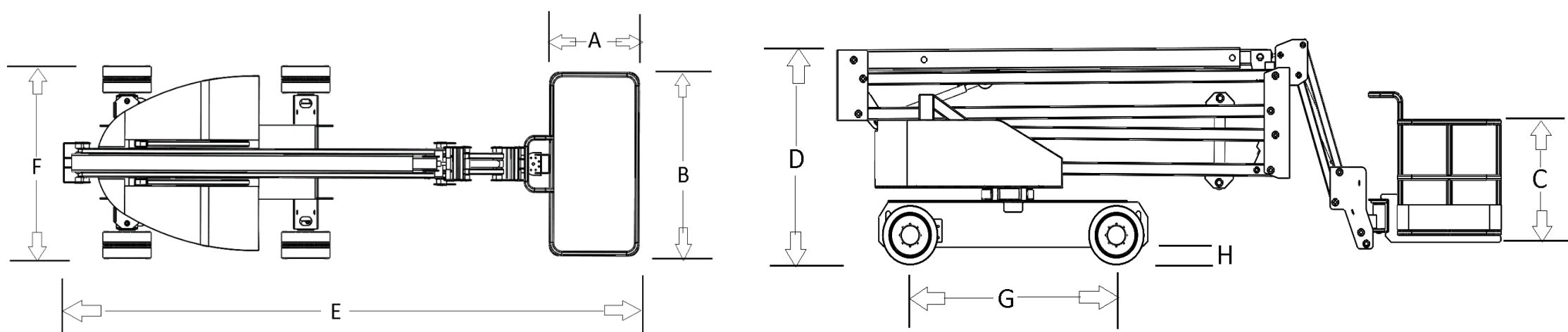

Fig. 3

\* The metric equivalent of working height adds 2 m to platform height.

\*\* Max Occupancy should not in any circumstances be more than 2

\*\*\* Weight will vary depending on options and/or country standards.

Note : Images are for reference only. They are not to be considered for actual visual appearance.