



Articulated Boom Lift

Model : DBA-16 / 7

PAP-A-5/4/5, Chakan Industrial Area, Phase-4, Nigoje Village, Tal - Khed, Pune - 410501

Contact: +91 8600117822 / 9011067039

Email: marketing2@daedalusind.com / sales@daedalusind.com

Specifications

Models		DBA-16 / 7	
Measurements		Feet	Metric
Maximum Working Height*		52 ft	16 m
Maximum Platform Height		45 ft	14 m
Maximum Horizontal Outreach**		26 ft	8.0 m
Platform Length		2.9 ft	0.9 m
Platform Width		6.5 ft	2.0 m
Guardrail Height		3.6 ft	1.1 m
Height	Stowed	7.5 ft	2.3 m
Vehicle Dimensions	Height	7.5 ft	2.3 m
	Length	24 ft	7.4 m
	Width	7.2 ft	2.2 m
Wheelbase		7.2 ft	2.2 m
Ground Clearance		0.7 ft	0.24 m

Productivity

Maximum Occupancy***		2 people
Lift Capacity		225 Kgs.
Platform Rotation		140 Degree
Vertical Jib Rotation		130 Degree
Turntable Rotation		340 Degree Non-Continuous
Gradeability****		30%
Drive		4 WD
Drive Speed	Stowed	4.8 kmph
	Raised	1.0 kmph
Turning Radius	Outside	3.3 m
Control		24 V DC
Tyres		23" X 10"

Power

Power Source	8 X 6V 225 Ah Batteries
Auxiliary Power Unit	24 V DC
Hydraulic tank Capacity	40 Ltr.
Weight*****	7500 Kgs.

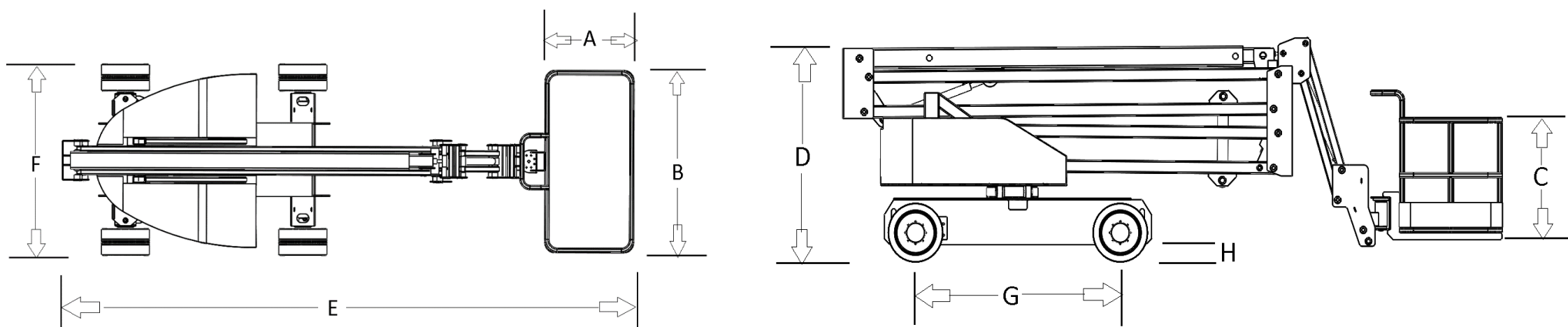

Fig. 3

* The metric equivalent of working height adds 2 m to platform height.

** Max Occupancy should not in any circumstances be more than 2

*** Weight will vary depending on options and/or country standards.

Note : Images are for reference only. They are not to be considered for actual visual appearance.